

Comb Offset Stabilization Module (COSMO)

Summary: The Octave Photonics Comb Offset Stabilization Module (COSMO) provides a compact and convenient solution for f - $2f$ self-referencing a laser frequency comb using nanophotonic waveguide technology. Additionally, the COSMO allows the carrier-envelope-offset frequency (f_{CEO}) to be detected with exceptionally low pulse energies, enabling lower power consumption and higher repetition rates.

Usage: The COSMO connects to the laser with an FC/APC fiber connector and provides an electrical output that can be connected to standard stabilization electronics. The pulse must be compressed at the entrance to the COSMO housing, so an appropriate length of fiber and/or dispersion-compensating fiber should be used by the customer. Additionally, control over the input pulse energy allows the signal-to-noise ratio of the f_{CEO} signal to be optimized.

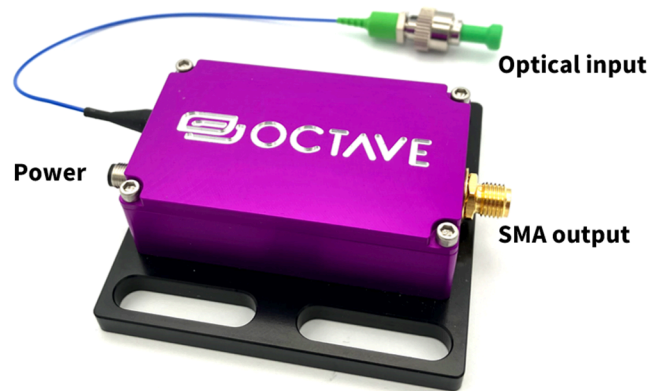
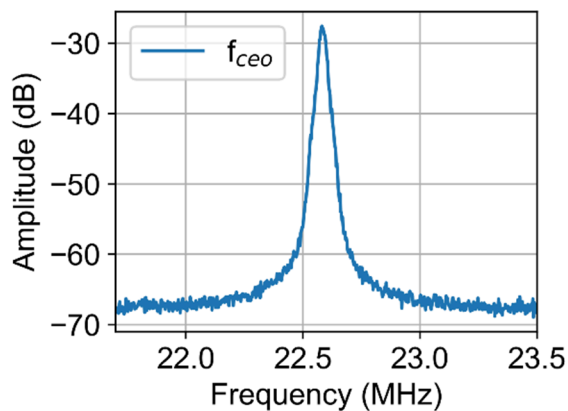

Specification	COSMO
Input pulse wavelength	~1560 nm
Minimum pulse energy for CEO detection	150 pJ typical 200 pJ max.
Maximum input pulse energy	1 nJ
Recommended input pulse duration	<250 fs
Input fiber	PM1550
Input optical connector	FC/APC
Output electrical connector	SMA
Dimensions (excluding connectors)	57x35x17 mm
Typical electrical power draw	0.6 Watts (50 mA @12 V)
Weight (without baseplate)	70 grams
Operating temperature*	5 to 40 C
Signal-to-noise ratio of CEO peak**	>35 dB (300 kHz RBW)

* Contact Octave for qualification of COSMO units over a larger temperature range.

** Observed signal-to-noise ratio depends on laser stability. >35 dB assumes a low-noise laser system.

See Ordering Details on Page 3



Schematic and dimensions:

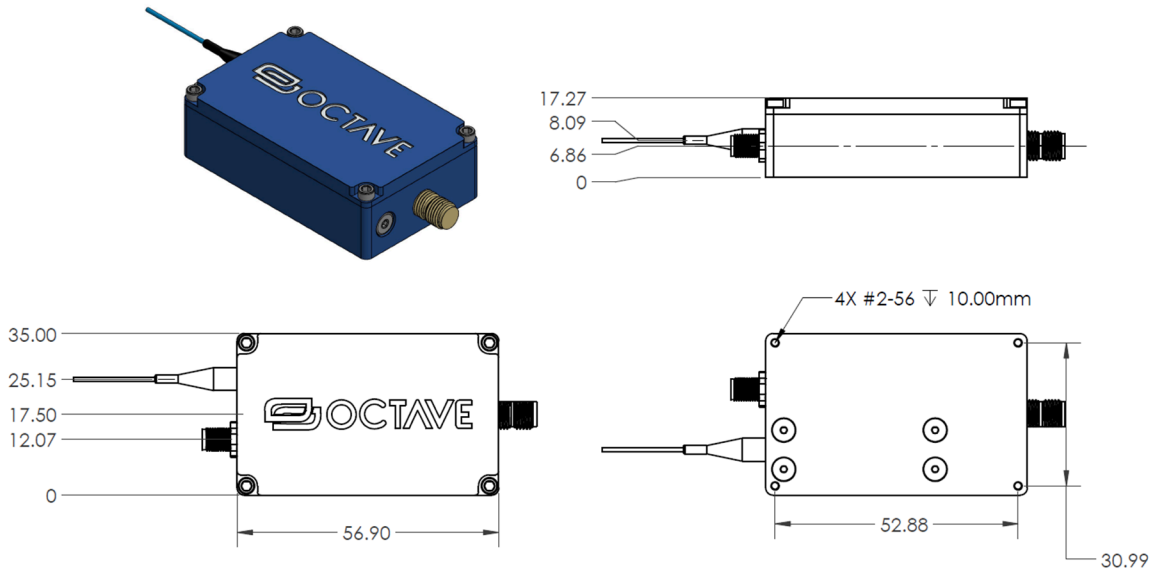

Dimensions are in millimeters. The SMA connector carries the CEO signal from detector. The 4-pin M5 connector provides inputs for detector power. The COSMO ships with an optional baseplate (not shown) to attach to standard optical tables.

Example offset detection: In this simple configuration, the COSMO is connected to an Er:fiber laser. The RF spectrum analyzer shows three peaks: f_{CEO} , $f_{CEO} - f_{rep}$, and f_{rep} , where f_{rep} is the laser repetition rate.

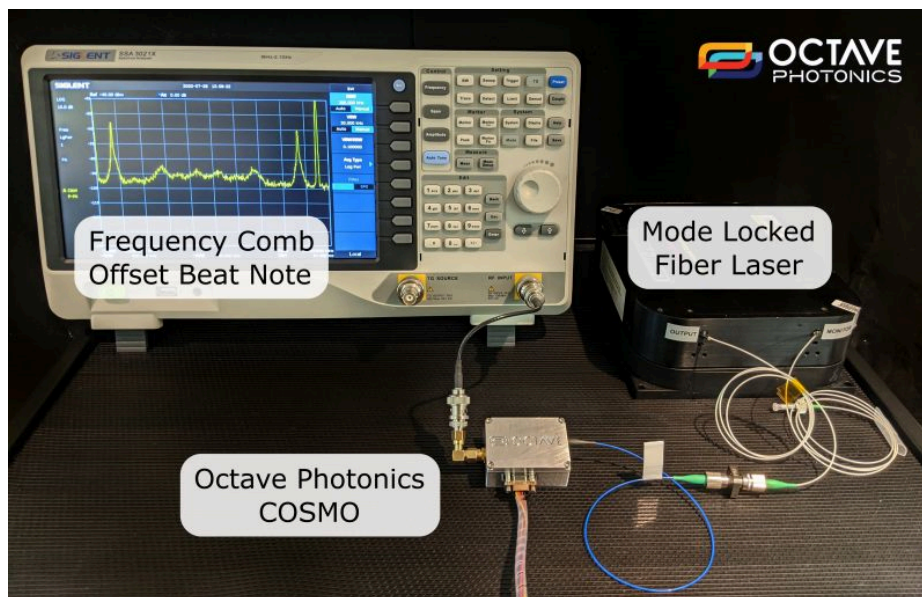

COSMO Ordering Information:

Part Number: COSMO-F-P-L/T

F: f_{ceo} frequency range

100M: <100 MHz

1G: <1 GHz

This is the 3 dB bandwidth of the internal photodetector. We typically recommend dividing your laser repetition rate by two and choosing the closest available value.

P: Full-width at half-max pulse duration

150: <180 fs (standard configuration)

200: 180-250 fs

If you know the compressed pulse duration of your laser, selecting this value accordingly can help minimize the threshold power for measuring a high SNR f_{ceo} beat signal.

L/T: Input fiber length and tolerance

X: Unspecified or non-critical. Defaults to 35±5 cm.

L: PM1550 fiber length in cm

T: Length tolerance in cm (+/-5 cm is typical)

Optimizing the pulse compression is key to making the COSMO work well. If you know how much PM1550 fiber it takes to compress your laser pulses, specify it here.

Examples:

COSMO-100M-150-X: COSMO with a 100 MHz photodetector for use with 120-180 fs input pulses. Default input fiber length.

COSMO-1G-200-30/2: COSMO with a 1 GHz photodetector for use with 180-250 fs input pulses. Input fiber length is 30±2 cm.

Note: The COSMO typically has a threshold pulse energy for CEO detection of ~150 pJ with 100 fs pulses. However, pulse duration, pulse quality, and unit-to-unit variations can increase the threshold. Thus, the standard COSMO is specified to have a threshold pulse energy for CEO detection of less than 200 pJ. If your application requires lower pulse energy, please contact Octave.



COSMO-Mini: While the COSMO already allows for the detection of f_{CEO} in an exceptionally compact package, Octave Photonics also offers the COSMO-mini, which is a fraction of the size of the regular COSMO. The COSMO-mini does not include the transimpedance amplifier that is built into the standard COSMO, instead providing direct access to the pins of the photodiode. The COSMO-mini weighs only 15 grams and has a volume of less than 4 cm³.

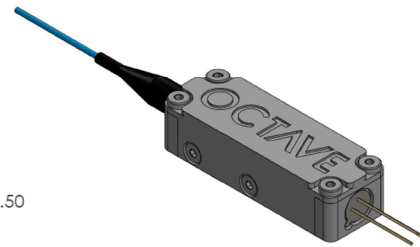
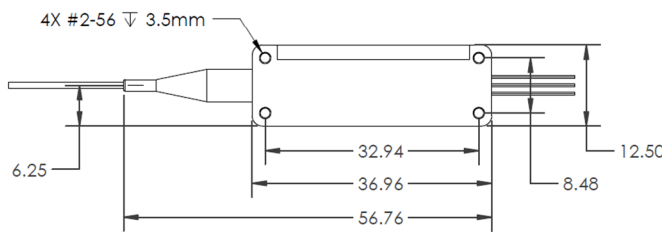
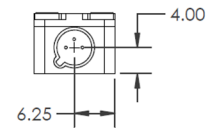
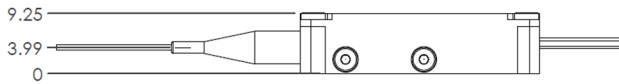

COSMOO for high repetition rate: For repetition rates higher than 2 GHz, the standard COSMO typically cannot be used. In such cases, we offer the COSMO with Optical output (COSMOO), which uses a lens to provide a collimated beam. The user can direct the beam to an appropriate high-speed photodetector to measure f_{CEO} .

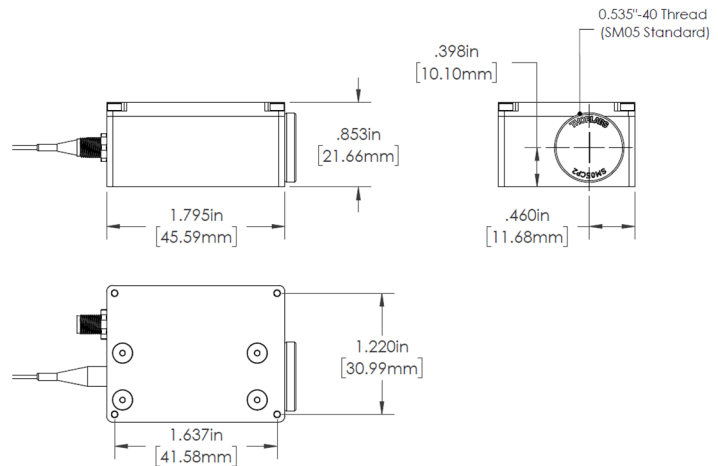
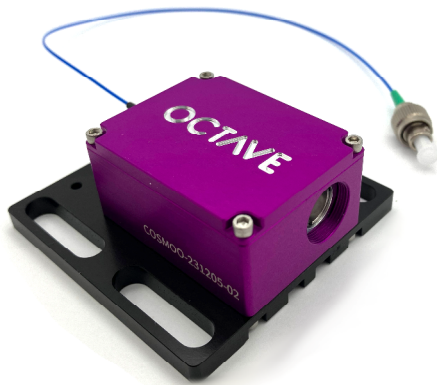

Left: The COSMOO on a baseplate that allows mounting to a standard optical table. Right: COSMOO engineering drawing.

Protecting against optical damage

Nanophotonic waveguides combine extremely tight optical mode confinement with high material nonlinearity. This combination allows low-energy input pulses to reach peak intensities nearing 10^{12} W/cm². However, since these intensities approach the optical damage threshold of the waveguide material, **special care must be taken to ensure the seed laser system does not output large transient pulses. Uncontrolled pulse amplification will permanently damage the waveguide module.**

The most common scenario for optical damage in a research-lab setting is when an optical amplifier is energized before a stably mode-locked seed laser is connected. This can happen, for example, if the seed laser loses its mode-locked state while the amplifier is running. To prevent damage, the amplifier must be turned off before re-modelocking the seed laser if the waveguide module is connected to the amplifier output.

To protect sensitive waveguide modules from this kind of damage, Octave Photonics offers a companion product called the Fast Laser Amplifier Interlock Module (FLAIM) to quickly turn off an optical amplifier system in the event of momentary or extended disruptions of the seed light. The FLAIM is a compact benchtop module that provides an adjustable input threshold for tripping the protection circuitry, shutting off the connected amplifier with a response time <1 ms. When used properly, the FLAIM can protect valuable nanophotonic components from accidental damage in laboratory environments.

